



TYPICAL

YSC-8701

USER MANUAL

XI'AN TYPICAL INDUSTRIES CO.,LTD.

Contents

Page

1	Notice	2
1.1	Work environment	2
1.2	Notice of installation	2
1.3	Notice of safety	2
2	Installation and Adjustment	3
2.1	Dimension of controll box	3
2.2	Adjustment of speed controller	3
2.3	Dimension of servo motor	3
3	Power Connection	4
3.1	Single phase 220V power connection	4
3.2	Three phase 380V power connection	4
4	Connector Diagram	5
5	Operation of the Front Panel	6
5.1	Diagram of the front panel	6
5.2	Setting of speed	6
5.3	Select of trimming type	6
5.4	Select of machine type	6
6	Measurement of Error and Warning	7
7	Signal Checking	7
7.1	Speed controller	7
7.2	Switch signal	7
7.3	Hall signal of servo motor	8
7.4	Encoder of servo motor	8
7.5	Solenoid function	8
7.6	Version of software	8
8	How to Enter Lasting Mode	8
9	Measurement of History Errors	8

1. Notice

YSC-8701 is used in system of industry sewing machine. For perfect operation and safety, installation and operation must be supervised by professional.

1.1 Work environment

Please use 220V AC in 10% ranges.

- ▲ To avoid the false operate, please keep the product away from the high electromagnetic interference.

Please operate in the area which temperature is 5 ~45 .

- ▲ Please operate in the area which humidity is 80% or less.
- ▲ Please keep the product away from the flammability and exploder.

1.2 Notice of installation

- ▲ The control box should be installed correctly follow the instruction in this manual.

Turn off the power and unplug the cord before installation.

- ▲ The wire must not set to be near the wheel and other movable parts.
- ▲ To avoid the static interference and current leakage, all grounding must be done.

1.3 Notice of safety

- ▲ Turn off the power before maintenance and repairs or raising the machine arms, or changing needle, or threading needle.

Please don't open the box except the professional.

- ▲ When turn on the machine in the first time, use low speed to operate and check the correct rotation direction.

During machine operation, don't touch any moving parts.

- ▲ All moving parts must use the protective device to avoid the body contact and objects insertion.

- ▲ When there is water or other liquid, or caustic material on box or motor, you must stop operation and turn off the power.

All connector shouldn't be plug and unplug when power on.

- ▲ The connector should be plug and unplug in the correct method.

2. Installation and Adjustment

2.1 Dimension of control box

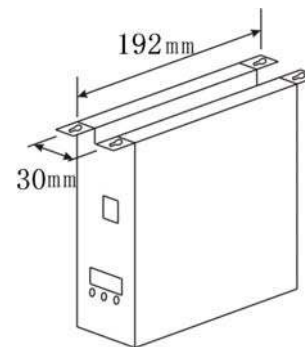

2.2 Adjustment of speed controller

- A Forward spring
- B Groove
- C Bolt group
- D Back spring
- E Hook hole for pedal

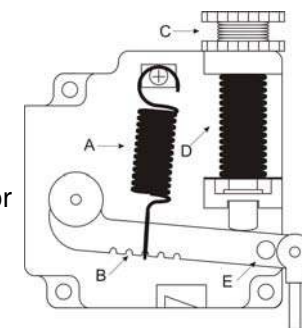

2.3 Dimension of servo motor

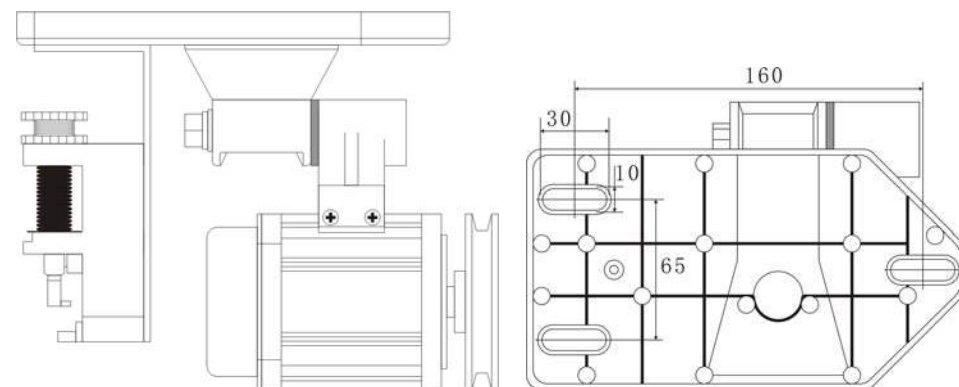

3. Power Connection

3.1 Single phase 220V power connection

Ground wire (green/yellow) must be grounding.

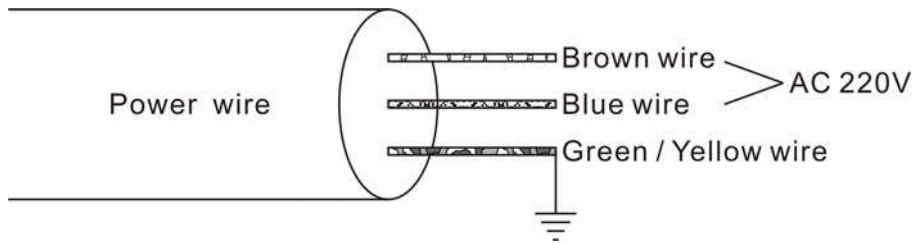

3.2 Three phase 380V power connection

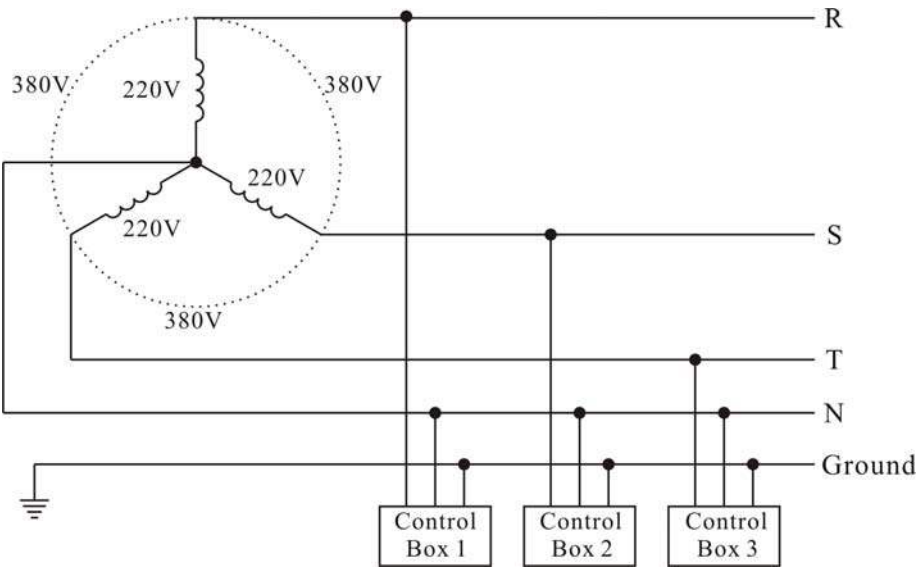

4. Connector Diagram

220V AC

	AC Power
1	Null Line
2	Live Line
3	Ground

(M)

	Motor
1	A Phase
2	Ground
3	B Phase
4	C Phase

(M)

	Encoder
1	--
2	QEB
3	W Hall
4	U Hall
5	+5V
6	UP
7	QEA
8	V Hall
9	GND
10	--

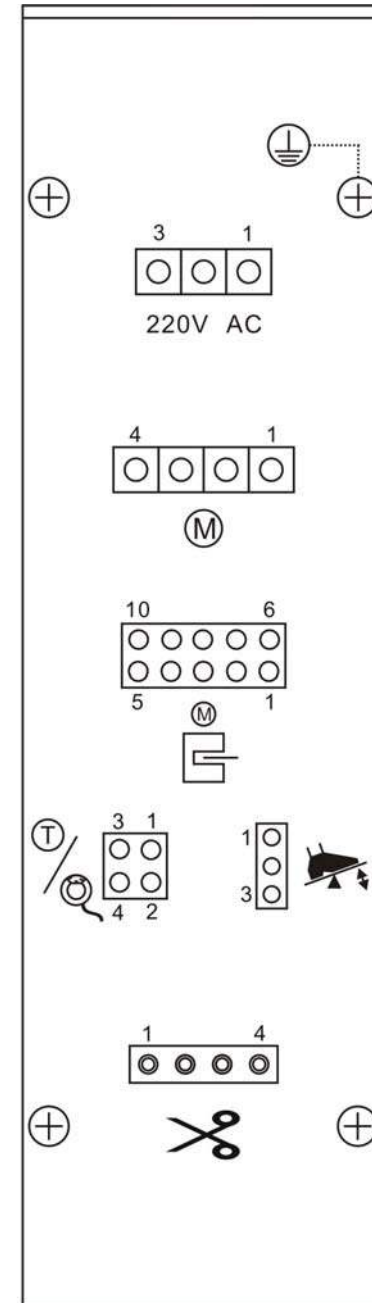

(S)

	Speed Controller
1	+5V
2	GND
3	Output

(T)

	Trimming SW.
1	Trimming SW.
2	--
3	+5V
4	--

(T)

	Cloth Detector
1	Signal
2	GND
3	--
4	+15V

(S)

	Function
1	Ground
2	Trimmer SOL. (MT)
3	--
4	+30V

5. Operation of the Front Panel

5.1 Diagram of the front panel

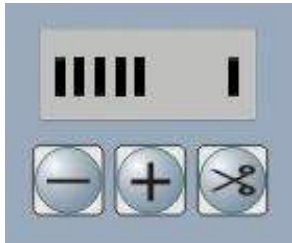

图示	Display area
	Display area. The left 8 bits indicate the speed, the right bit indicate the trimming type.
	Sub
	Add
	Trimming enable

5.2 Setting of speed

Thought and to set the max speed. to 150s/m,

to 6000s/m. The default is 4000s/m (

5.3 Select of trimming type

Select the trimming type through , trimming can be active by pedal if the right bit is light. The default is light

5.4 Select of Machine type

The system support trimming switch or cloth detector.

Press during power on, the trimming switch function is valid if display , the cloth detector is valid if display . It can be switched through .

6. Measurement of Error and Warning

If fault appearing, panel will twinkle to alarm.

Error code	Causation	Measurement
1 bit twinkling(E1)	Voltage is too high	Check the AC power
2 bits twinkling(E2)	Voltage is too low	Check the AC power
3 bits twinkling(E3)	Load is too heavy	Check the load
4 bits twinkling(E4)	Pedal error	Check speed controller, see section 7.1
7 bits twinkling(E7)	Pedal warning	Release the pedal

7. Signal Checking

Press during power on, then enter the mode of Measurement of Input Signal. Press to change the checking item, press to show currently SN.

7.1 Speed controller (SN:)

Display of the different pedal position as below:

Display code	Meanings	Descriptions
	High speed	The second segment forward
	Low speed	The first segment forward
	Balance	Default.
	Trimming	The segment of backward.
Twinkling	Fault	fault or disconnected.

7.2 Switch signal (SN:)

Showing the state of trimming switch or cloth detector.

Display code	Meanings
	Trimming switch valid / With cloth
	Trimming switch invalid / Without cloth

7.3 Hall signal of servo motor (SN: ■■■)

Turn the hand wheel by hand equably, display the hall signal of motor as below. Twinkling when fault state appeared.

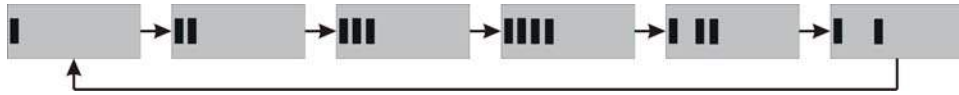

7.4 Encoder of servo motor (SN: ■■■)

Turn the hand wheel by hand equably, display the encode count of motor.



7.5 Solenoid function (SN: ■■■)

Through  to test the trimmer SOL.

7.6 Version of software (SN: ■■■)

For example, the version is v 01 .



8. How to Enter Lasting Mode

Press  and  during power on, then enter the lasting mode.

9. Measurement of History Errors

The system can save the error code automatically when error occurred.

Checking the history error by operation as below:

- Press  and  during power on;
- ▲ Press  to check the 8 error code of recent;
- ▲ Display empty if there is no error;
- ▲ Else display the error code, see section 6.
- ▲

Add: No.1 Taibai South Road,
Xi'an, P.R.China-710068
Tel: +86-29-88279162 88279163
Fax: 029-88279161 83911111
E-mail: typical@chinatypical.com
Http://www.chinatypical.com